

# POWER SPECIFICATION

## 1. INTRODUCTION

### 1.1 Product Description

This specification defines the input, output, performance characteristics environment, noise and safety requirements for a Power Supply .

### 1.2 Parameter Specification

Unless specification otherwise, all parameters must be met over the limit of temperature Load, and input voltage.

## 2. ELECTRICAL REQUIREMENTS

### 2.1 Input Requirements

#### 2.1.1 Input Voltages

- Normal Voltage: 100 ~ 230 Vrms
- Voltage Range : 90 ~ 264 Vrms

#### 2.1.2 Input Frequency

- Normal Frequency: 50 ~ 60Hz
- Frequency range : 47 ~ 63Hz

#### 2.1.3 Input Current

- under 2.0 Arms at 90Vac to 264Vac & load Max

#### 2.1.4 Configuration

- 2 Conductors (Live, Neutral)

#### 2.1.5 Input Fuse

- The live line side of the input shall have a fuse.

#### 2.1.6 Primary Over Current Protection

- An adequate internal fuse on the AC input line shall be provided.

#### 2.1.7 Inrush Current

The inrush current of power supply shall be less than the rating of its critical components (including bulk rectifiers and surge limiting device) for all condition of line voltage of 2.1.1

- Cold start: under 50Ap-p at AC 220Vac (Wall-Out)

#### 2.1.8 Efficiency

The power supply efficiency shall be more than 80% measure at the 90Vac maximum load as specified in paragraph 2.2.1 with the AC input set at the nominal voltage.

2.2 Output Requirements  
2.2.1 Electrical characteristics

No	Item	Condition		Specification		
				MAIN	Module	Inverter.
1	Output Voltage	Rating	Load Max (refer to #2 MAX)	5V	15V	15V
		Tolerance		4.6V~5.3V	13.5V~18V	13.5V~18V
		Ripple(mA)	Load Max (*1)	300	500	500
		Cross reg1 (sound mute)	1.15V : Variable 2.Other : Max.	4.6V~5.3V	13.5V~18V	13.5V~18V
		Cross reg2 (off mode)		-	-	-
2	Load Current	TOTAL Max.	Test & Aging Standard (Po= 65.0W)	2.5A	1.5A	2.0A
3	Inrush Current	Inrush	Possible Range Refer to (주2)			
		Duration				
4	SCP	Yes,No	1. Check Line : Short to GND 2. Other : Load Max	Yes	Yes	Yes

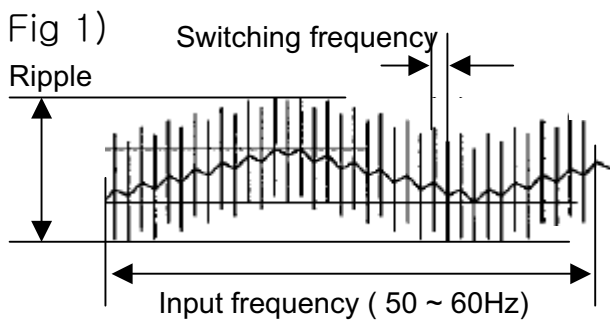

주1) Ripple Test

- 1-1) Test 방법 : Ripple test는 fig 1을 따른다
- 1-2) Test Point : power output 각 pin

주2) Inrush current

- 2-1) power가 cover할 수 있는 range를 의미함.
  - 2-2) spec over시 voltage dip, 부품 dead가능성 있으므로
- 명기된 spec 이상 사용하지 말 것.

주3) Load current : 업체 Aging / RQA test standard

\* Power On/Off Voltage : 3V ~ 5V

주4 ) Test Point : power output 각 pin

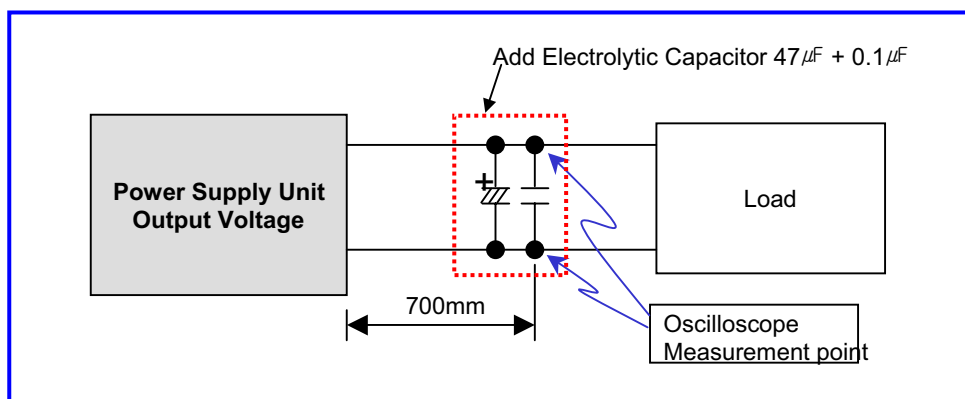

※ Ripple and noise are measured at the end of output cable which are added a 0.1uF ceramic capacitor and 47uF electrolytic capacitor.(connected parallel)

2.2.2 Output Voltage Requirement

The total output voltage regulation shall be  $\pm 5\%$ , including the effects of line voltage variation, load current, ripple and noise, and the AC component of the load Current.  
The effect of dynamic load changes is not included in this limit.

2.2.3 Overshoot

The output overshoot at turn –on shall not exceed 10% of normal voltage value with or without the load connected.

2.2.4 Hold up Time

The power supply shall maintain voltage regulation within the specified limits in paragraph 2.2.1 for at least 32ms after lost of input voltage measure at 100Vac and at maximum output load.

2.2.5 Output Rise Time

At turn on the rise time of output voltage shall be less than 20msec.  
※ Measured from the 10% point to the 90% point of the normal

2.2.6 STAND BY POWER CONSUMPTION

Output Voltage	STB 5V	15V	15V
Load [A]	0.06	-	
Wattage [W]	0.9W Under (230Vac / 50Hz)		

☞ Test condition

- Temperature: 25°C room temperature
- Test equipment: Electronic load → CR-mode(Continuously resistance)

2.3 Power Output Protection

2.3.1 Over Current Protection(OCP)

The power supply shall not be damaged by over current load.  
The OCP function must be operated if current exceed maximum rating.

- ☞ The OCP point is measured when other output load is a maximum.  
At this time, no hardware failure and No fire, when the output voltage decrease to 0V(shutdown)

2.3.2 Over Voltage Protection(OVP)

The voltage will not exceed the upper trip limit.  
Noise spikes that exceed the lower trip limit for less than 10 $\mu$ S will not clamp the output voltage to zero.

2.3.3 Short Circuit Protection(SCP)

An output short circuit is defined as output impedance of less than 0.1 ohms.  
The power supply shall not be damaged by short between DC output and DC ground.

### 3. RELIABILITY

#### 3.1 Mean Time Between Failure(MTBF)

The power supply shall be designed and produced to have a mean time between failures (MTBF) Of 40,000 operating hours at 90% confidence – level while operating under the following condition.

- AC input voltage : 110Vac and 230Vac
- Duty cycle : 6hours ON, 2hours OFF
- Ambient Temp. :  $25 \pm 2^{\circ}\text{C}$
- Humidity : prevailing condition

#### 3.2 Life/Power On Hours

The power supply must be designed to operate for 40,000 power on hours. About 5 years at an ambient temperature of  $25^{\circ}\text{C}$

#### 3.3 Burn-in Test Condition

More than 4 hours at  $40^{\circ}\text{C}(\pm 5^{\circ}\text{C})$ , Normal input voltage.  
AC on/off must be test 1 time after burn-in.

Output Voltage	5Vo	15Vo MODULE	INVERTER
Aging Load [A]	2.5A	1.5A	2.0A

☞ Test condition

- Test equipment: Electronic load → CR-mode(Continuously resistance)

### 4. SAFETY & EMS

 Safety

#### 4.1 Earth Leakage current

The power supply leakage current shall be less than 0.5mA

#### 4.2 Hi-Pot Test(Dielectric withstand voltage)

- ① Primary to Secondary : 3.0KVac for 1 minute  
→ 3.6KVac for 1 seconds (mass production)
  - ② Primary to F.G : 1.5KVac for 1 minute  
→ 1.8KVac for 1 seconds (mass production)
- ※ Cut-off current : 10mA

#### 4.3 Insulation Resistance

Insulation resistance shall be  $8\text{M}\Omega \sim 12\text{M}\Omega$  at 500Vdc between primary Live, Neutral line and secondary.

#### 4.4 Input AC Surge

The power supply withstand 300Vrms input for 10 seconds.

#### 4.5 Surge & Impulse Test

- ① Lightning Surge :  $\pm 2\text{kV}(\text{L1} \sim \text{L2})$  3 time
- ② Impulse Noise Test : 2kV, Normal/Common mode, Polarity(+,-) / Phase( $0^{\circ} \sim 360^{\circ}$ )

#### 4.6 RFI / EMI Standards

The power supply shall comply with a following RFI/EMI standards when tested in a system configuration.

- F.C.C federal rules and regulations part 15, sub parts B computing device.
- CISPR22, class B. "NORDIC/EUROPE"

The limits shall be met with a margin of at least more than 6dB at all applicable frequencies.

#### 4.7 Safety Standards

The Power Supply Unit shall be tested with the following safety standards.

- UL1310, UL1950 (Safety of information technology equipment) listed. "USA"
- CSA C22.2, NO234 level 3 output, class 2 output. "CANADA"
- CB Report : IEC60065, IEC60950

### 5. ENVIRONMENT REQUIREMENTS

#### 5.1 Temperature

- Operating Temp. : 0 ~ 60°C (※0 ~ 40°C: with Case)
- Storage Temp. : -20 ~ 60°C

#### 5.2 Humidity

- Operation humidity : 30 ~ 85% non-condensing
- Storage humidity : 5 ~ 90% non-condensing

6.Mechanical requirements

6-1. Power supply Dimension Constraints

196.0(L) \* 156.0(W) \* 20.0(H) mm.

